



RIKO RT

Data sheet

RTV 5

Single-chamber baling press RTV 5

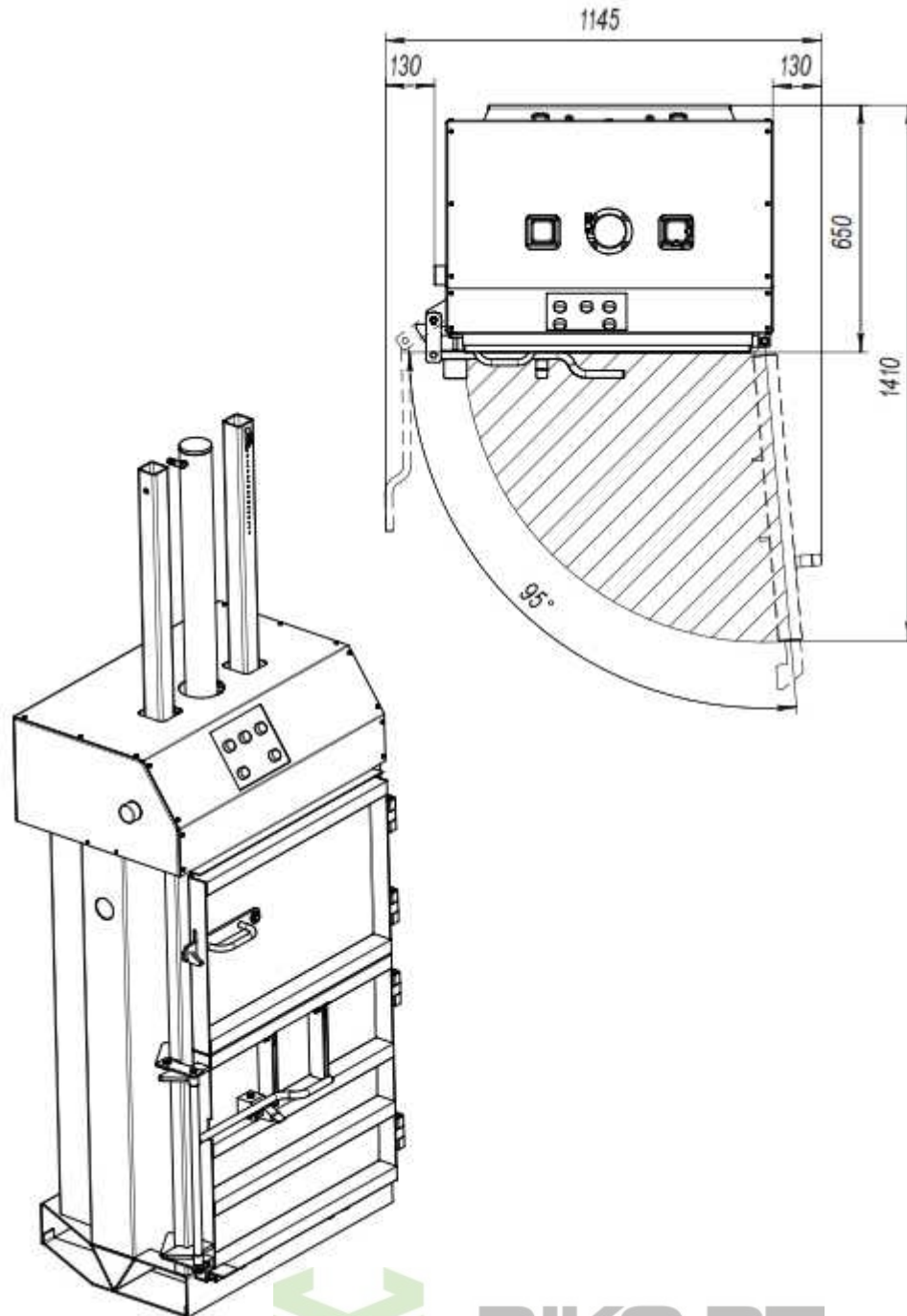

RIKO RT

All dimensions in mm



Power supply:	230 V 50 Hz
Electrical Power:	1,5 kW
Protection class:	IP54
Pressing force:	5
Press stroke:	670
Weight of the machine:	370
Transport dimensions (l _w xh):	1200 x 750 x 2320 (/ lowered) 1200 x 750 x 1930
Filling opening (w _x h):	700 x 500
Cycle Time:	30
Bale weight *:	60
Bale size in the chamber (l _w xh)*:	700 x 700 x 500
Bale tying:	strapping with two twines
Comment:	two-hand operation

*

**RIKO RT**

(1:02 1:04).

The bale size and bale weights are approximate dimension and depending on the material. The information refers to cardboard packaging (quality 1.02 and 1.04). Information about other materials on request.

We reserve the right to make dimensional and design changes.